



Drilling hole template for **Blazer**

Adjust: 100%



Please print the paper, carefully cut along the dotted outline, affix it to the body as shown using the markers on the body to ensure perfect alignment, and drill the screw holes as depicted in the diagram.

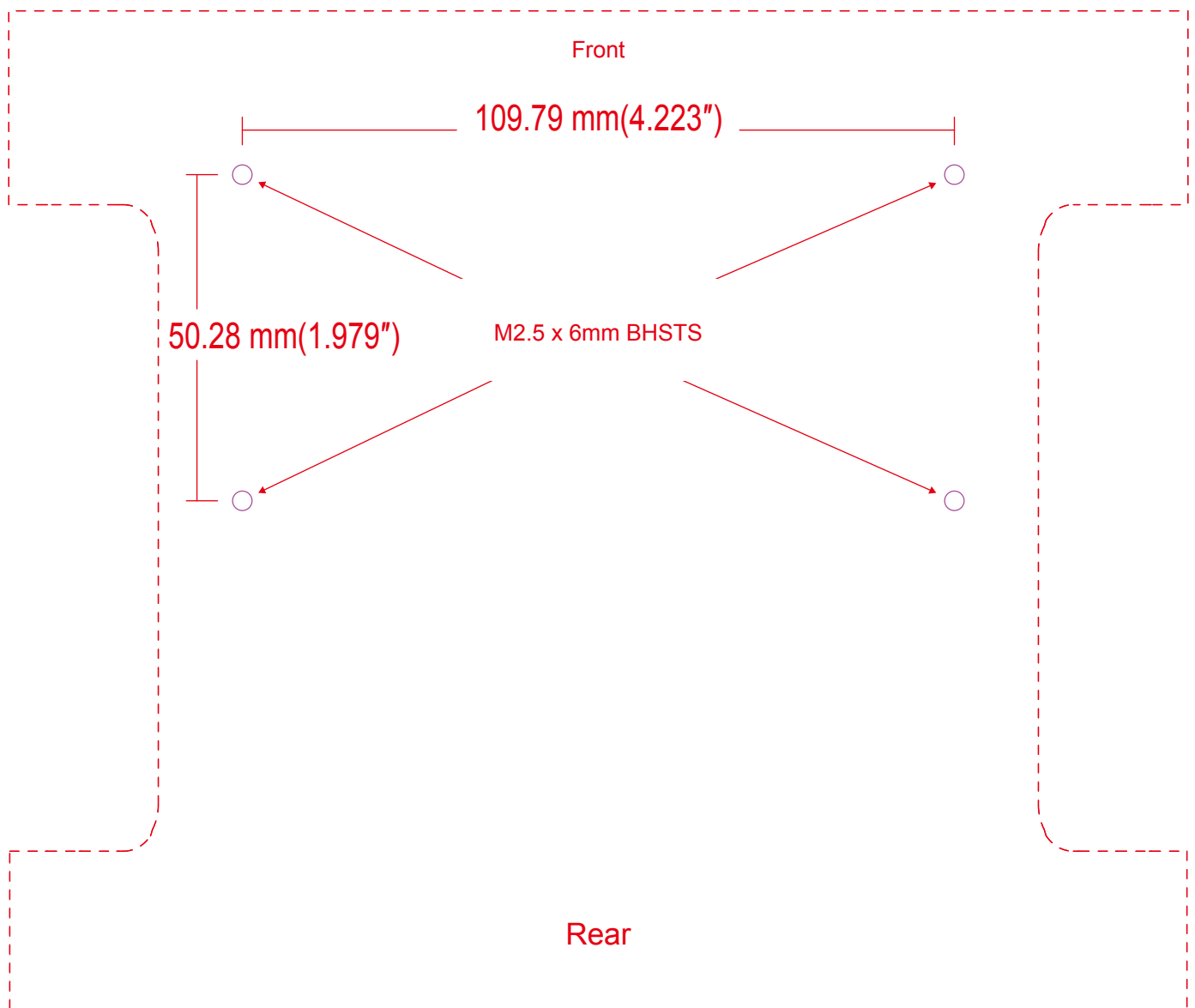



Drilling hole template for Blazer

Installation steps

Step 1.

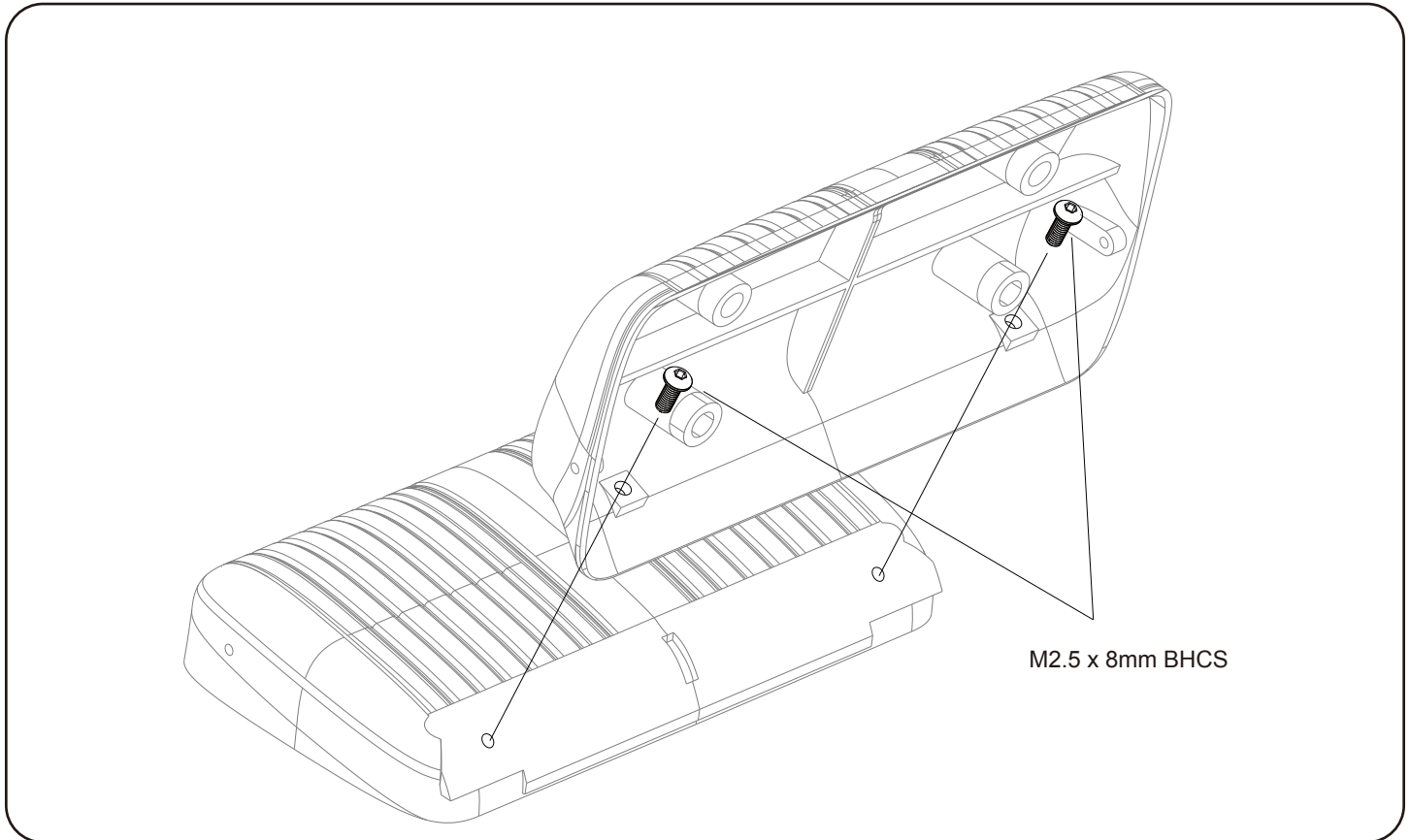

Step 2.

